

Marley Typhoon® Spouting System



Marley New Zealand uPVC spouting and downpipe systems are designed for the collection and discharge of rainwater from roof areas.

Typhoon® Spouting:

- › Excellent capacity and flow characteristics.
- › Half-round profile.
- › Internal or external brackets.
- › Designed for the efficient flow of rainwater when used in conjunction with Marley's RP80® 80mm round downpipe system.

Colours available:



Technical Details – Typhoon® Spouting

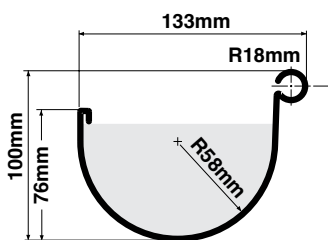

Effective Cross Sectional Area: 6100mm²

Flow Capacity: 87 litres/minute

Material: uPVC (Unplasticised PVC)

Minimum Recommended Fall: 1:2000 (0.5mm per 1m)

Bracket System: Internal or External bracket options. To be spaced at max 500mm centres (reduce to 300mm in high wind or snow prone areas)

Components of the system

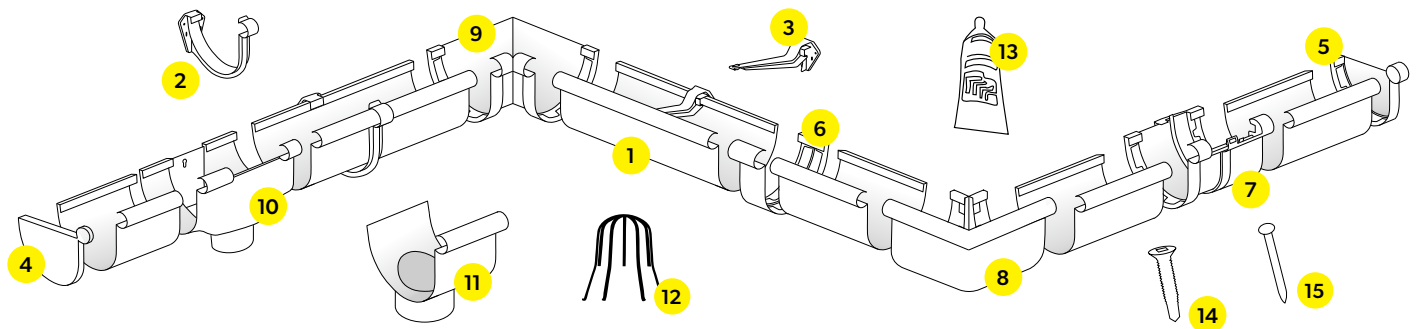

Table 1: System Components

COMPONENT	WHITE	GREY FRIARS®	IRONSAND®	BLACK	FLAXBLACK®	TITANIUM	COPPER
1 Typhoon Spouting 5m Length	MT1.5						
1 Typhoon Spouting 4m Length		MT1.4.GYF	MT1.4.IRO	MT1.4.BLK	MT1.4.FXB	MT1.4.TTN	MT1.4.COP
1 Typhoon Spouting 3m Length	MT1.3						
2 Typhoon External Bracket	MT2E	MT2E.GYF	MT2E.IRO	MT2E.BLK	MT2E.FXB	MT2E.TTN	MT2E.COP
3 Typhoon Internal Bracket	MT2I	MT2I.GYF	MT2I.IRO	MT2I.BLK	MT2I.FXB	MT2I.TTN	MT2I.COP
4 Typhoon Left Hand Stopend	MT3	MT3.GYF	MT3.IRO	MT3.BLK	MT3.FXB	MT3.TTN	MT3.COP
5 Typhoon Right Hand Stopend	MT4	MT4.GYF	MT4.IRO	MT4.BLK	MT4.FXB	MT4.TTN	MT4.COP

COMPONENT	WHITE	GREY FRIARS®	IRONSAND®	BLACK	FLAXBLACK®	TITANIUM	COPPER
6 Typhoon Spouting Joiner	MT5	MT5.GYF	MT5.IRO	MT5.BLK	MT5.FXB	MT5.TTN	MT5.COP
7 Typhoon Expansion Joiner	MT17	MT17.GYF	MT17.IRO	MT17.BLK	MT17.FXB	MT17.TTN	MT17.COP
8 Typhoon External Angle 90°	MT6	MT6.GYF	MT6.IRO	MT6.BLK	MT6.FXB	MT6.TTN	MT6.COP
9 Typhoon Internal Angle 90°	MT7	MT7.GYF	MT7.IRO	MT7.BLK	MT7.FXB	MT7.TTN	MT7.COP
10 Typhoon Expansion Outlet 80mm	MT8.80	MT8.80.GYF	MT8.80.IRO	MT8.80.BLK	MT8.80.FXB	MT8.80.TTN	MT8.80.COP
11 Dropper Outlet 80mm	MT11.80	MT11.80.GYF	MT11.80.IRO	MT11.80.BLK	MT11.80.FXB	MT11.80.TTN	MT11.80.COP
12 Outlet Strainer	RWST	RWST	RWST	RWST	RWST	RWST	RWST
13 Solvent Welding Cement 180g Tube	MCS	MCS.GYF	MCS.IRO	MCS.BLK	MCS.FXB	MCS.TTN	MCS.COP
14 Bracket Screws for Metal Fascia	SCREW.METAL	SCREW.METAL	SCREW.METAL	SCREW.METAL	SCREW.METAL	SCREW.METAL	SCREW.METAL
15 Bracket Nails	MCNAILS	MCNAILS	MCNAILS	MCNAILS	MCNAILS	MCNAILS	MCNAILS
Special Spouting Angle - Flat	MTSPEC.F	MTSPEC.F.GYF	MTSPEC.F.IRO	MTSPEC.F.BLK	MTSPEC.F.FXB	MTSPEC.F.TTN	MTSPEC.F.COP
Special Spouting Angle - Rake	MTSPEC.R	MTSPEC.R.GYF	MTSPEC.R.IRO	MTSPEC.R.BLK	MTSPEC.R.FXB	MTSPEC.R.TTN	MTSPEC.R.COP

Most of the products mentioned in Table 1 are manufactured by Marley NZ, however some of them may be sourced from reputable companies.

Manufacturer

Marley New Zealand Limited

- › 32 Mahia Rd, Manurewa, Auckland – New Zealand
- › 0800 627539
- › www.marley.co.nz
- › info@marley.co.nz
- › NZBN: 9429038863431

Others

Bostik New Zealand Ltd

- › 19 Eastern Hutt Road, Wingate, Lower Hutt, Wellington 5019
- › www.bostik.com
- › nzsales@bostik.com

Anzor Fasteners Ltd

- › 93 Apollo Drive, Albany, Auckland
- › www.anzor.co.nz
- › accounts@anzor.co.nz

NZ Nail Industries Ltd

- › 809A Great South Road, Mount Wellington, Auckland 1643
- › www.nznails.co.nz
- › accounts@nznails.co.nz

Relevant Building Code Clauses

The Typhoon® Spouting System when used, installed, and maintained in accordance with the requirements outlined in this document, will meet or contribute to meeting:

- › NZBC Clause B2: Durability. Exceeds the requirement NZBC B2.3.1 c) 5 years.
- › NZBC Clause E1: Surface Water. Meets the requirements for NZBC E1.3.3 (a), (b), and (d).
- › NZBC Clause F2: Hazardous Building Materials. Meets this requirement and will not present a health hazard to people.

Quality Assurance

Product batch release testing is conducted by Quality Control systems according to manufacturing standards at the site of manufacture. All product compliance validation is conducted at the Marley IANZ Registered Laboratory (IANZ 92).

Limitations on the use

Marley uPVC spouting and downpipe systems are suitable **ONLY** as external spouting and downpipes and are **NOT** suitable for use as a concealed system or as an internal spouting system.

Guarantee

Marley guarantees the purchaser of Marley spouting or downpipe products against defects in material and manufacture for a period of 15 years from the original date of purchase. For more information refer to [Marley Guarantee](#).

Design

- › All the dimensions referenced are nominal.
- › Each Marley spouting system has a different flow capacity and cross-sectional area.
- › Marley recommends reducing the bracket spacing to 300mm maximum for areas subjected to high wind or occasional light snowfall.
- › Over time the components of the Marley spouting and downpipe system will weather. Weathering of the external surfaces does not affect the long-term durability of the system.
- › All Marley spouting systems feature a high front face and maintain a 10mm gap between the back face of the gutter and the fascia board so that water is able to overflow over the back face without entering the building envelope.

For more information refer to [Marley Spouting Systems Design Details](#).

Installation

A. Planning and Preparation

- › Establish the following:
 - › Downpipe/spouting outlet locations.
 - › Thermal expansion relief points.
 - › Spouting and downpipe lengths required.
 - › Fittings required.
- › Determine which direction the installation will be completed as the spouting must fall towards the outlets. Components should be solvent welded one after the other working in one direction. Use only Marley MCS solvent cement to ensure a watertight system.
- › Roof overhang should be no less than 50mm.
- › Marley spouting systems allow for the thermal expansion of uPVC using expansion outlets and expansion joiners.

B. Spouting installation

- › Marley recommends a minimum fall to the outlet of 5mm per 10m.
- › Brackets must be secured to the fascia with a maximum spacing of 500mm. In high wind areas prone to light snowfall reduce spacing to 300mm maximum.
- › Use a minimum of 3 fixings per bracket.
- › Use only Marley MCS solvent cement.
- › Expansion outlet: Set up the string line so that the bottom edge of the spouting brackets are aligned with the string line. Mark the position of the expansion outlet on the fascia. Fix the expansion outlet to the fascia using the side fixing tabs to align with the string line. The spouting is clipped into the expansion outlet. Do not glue.
- › Different scenarios may apply to any given job including:
 - › Spouting run to an expansion outlet.
 - › Spouting run with an expansion joiner.
 - › Spouting run to dropper outlet.

For more information refer to [Marley Stratus Design Series – Design and Installation Guide](#) Section 4.

Maintenance requirements

- › If spouting is at height or difficult to access, consider consulting a professional installation or maintenance company.
- › Check brackets, they should be spaced no more than 500mm apart.
- › Check that fall is no more than 0.5mm per 1m.
- › Clear debris.
- › Check expansion joiner seal (where an expansion joiner has been used).
- › Wash your Marley spouting system at least once a year.
- › If painting white spouting. Thoroughly clean surface. Apply one coat of acrylic undercoat, followed by one coat of acrylic topcoat. Apply a second top coat if necessary. Use only light colours.

For more information refer to [Marley Rainwater Systems Maintenance Schedule](#).

Warning and/or Bans

The Typhoon® system is not subject to any warning or ban.